



Unicla **UM** SERIES COMPRESSORS

With new mounting capability and MDM - Multi Direct Mounting System



UM330



UM200

Features

Unicla UM series compressors feature new mounting configurations to allow greater capability and flexibility for engine mounting.

The Multi Direct Mounting (MDM) system on the Unicla UM330, and as seen on Unicla UWX model compressors, provides four mounting points on the left, right and bottom sides of the compressor, making a total of twelve points. Each point is a threaded hole which allows excellent flexibility in engine mounting and bracket design.

The Unicla UM200 has four conventional bolt through mounting points which have been narrowed to 92mm and 87mm at the top and bottom respectively.

UM330

The Unicla UM330 model is an ideal compressor choice for designers of air-conditioning systems in many large commercial vehicle applications where the system capacity is between 10 and 14 KW, and the new MDM system allows greater flexibility for single unit mounting or in a twin or triple configurations on one engine.

The UM330 maintains the standard UX330 porting configuration with horizontal and vertical hose connection capability on each model. This is achieved by using heavy duty shipping caps on the outlets not in use. The compressors also feature the famous Unicla 10 cylinder swashplate design 330cc capacity and can be operated in a clockwise or counter-clockwise direction.

UM200

The Unicla UM200 model compressor has been designed to meet the demands of larger capacity single and twin air-conditioning systems fitted to vehicles in commercial and heavy duty working environments, such as mini bus, truck, tractor and mining applications. Also marine applications using eutectic evaporator systems are ideal for all Unicla 200 series compressors, and with the new narrower bolt through mounting points, fitting into tighter engine spaces now has greater flexibility. Vertical or horizontal hose ports are available, and the 10 cylinder operation with 200cc capacity can also be driven in a clockwise or ant-clockwise direction.

Clutches

A diverse range of clutches are available in AA, B section and Polygroove, and 12 or 24 volt. The featured compressors here show a 168mm 8 polygroove clutch fitted to the UM330, and a 145mm single B section clutch fitted to the UM200.

Service Valves

Low and high side service valves are fitted as standard and can be easily removed if not required. The low side valve can be placed in two positions on the compressor.

Oil Return Port

A Unicla Oil Return Port is fitted as standard on all 330 and 200 series compressors. It easily unscrews from the top oil filler plug position and can be interchanged with the low side service port. It is a standard male flare fitting and is suited to the Unicla Oil Separator part no.OS000010



Unicla **UM** SERIES COMPRESSORS

With new mounting capability and MDM - Multi Direct Mounting System

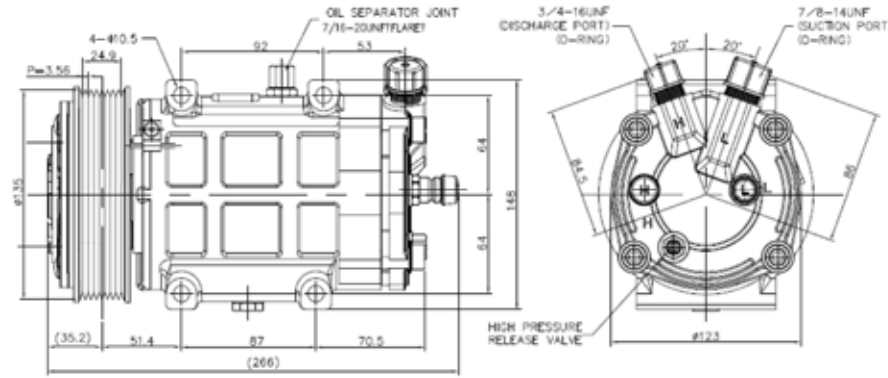

UM200

Side and rear view with 8 polygroove clutch with vertical oring hose ports

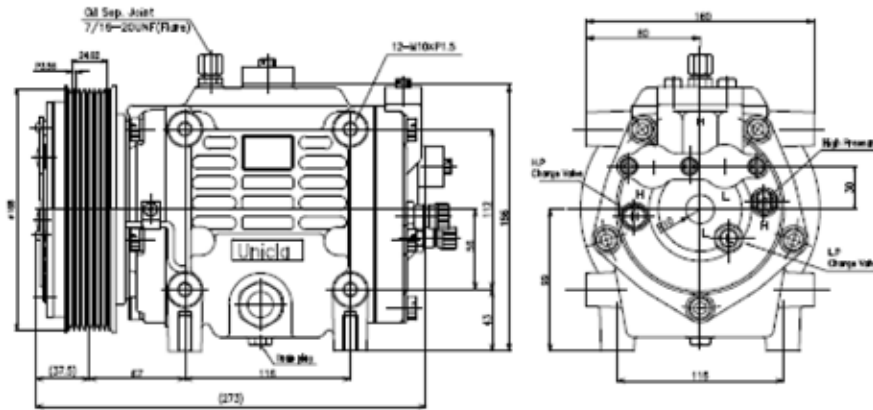

UM330

Side and rear view with 8 polygroove clutch (hose fittings not attached)

UM200 Performance data operating with R134a

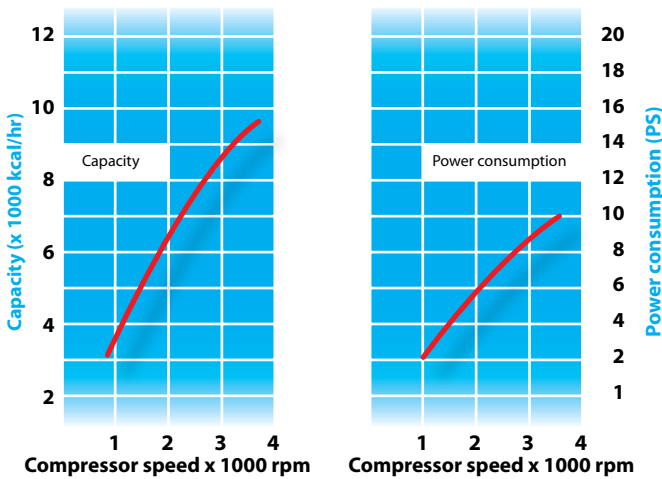

Operating Conditions	
Pressure suction	1.86kg.cm ² G
Pressure discharge	15.5kg/cm ² G
Super heat	10°C
Sub cooling	5°C

Specifications	
Model	UM200
Displacement	200cc/rev.
No. of cylinders	10
Max momentary speed	4500 rpm
Lubricant	Unidap 7 (PAG)
Initial oil charge	180cc

UM330 Performance data operating with R134a

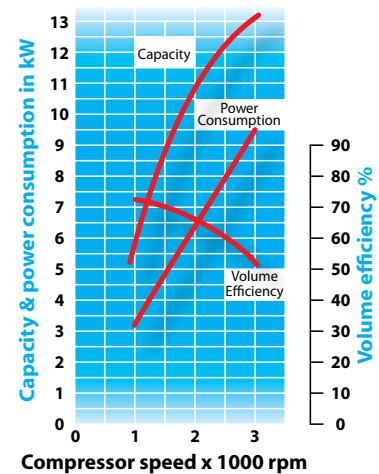

Operating Conditions	
Pressure suction	1.86kg.cm ² G
Pressure discharge	15.5kg/cm ² G
Super heat	10°C
Sub cooling	9°C

Specifications	
Model	UM330
Displacement	330cc/rev.
No. of cylinders	10
Max momentary speed	4500 rpm
Lubricant	Unidap 7 (PAG)
Initial oil charge	600cc

For detailed information about Unicla recommendations on such areas as fitting compressors in special applications, measuring compressor thermal and pressure loads, and calculating extra oil requirements in larger systems, we recommend you visit our website where expert advice from Unicla engineers can be found.



Unicla International Limited

Unit 1209-1210, 12F, Manhattan Centre, 8 Kwai Cheong Rd,
Kwai Chung, N.T., Hong Kong. Phone (852) 2422 0180 Fax (852) 2422 0680
Email: sales@unicla.hk Website: www.unicla.hk

Distributed by: