



Unicla *NEW PRODUCT BULLETIN*

New 550 SERIES with capacity unloader for bus and coach applications

UWX



UWX550-5200

- 610cc Capacity
- Heavy duty clutch
- R134a service ports
- Horizontal hose ports
- Multiple mounting points
- High pressure relief valve
- Twin sight glass for oil inspection
- PAG or POE Oil

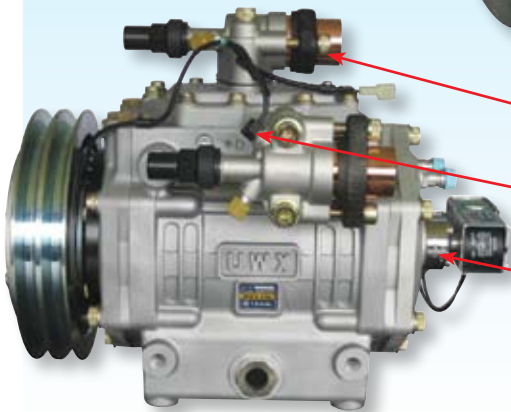

- Suction hose manifold
- Thermal cut-out switch
- discharge hose manifold - left or right hand side



- R134a Service valves
- Capacity unloader control unit
- Unloader solenoid

Features

The new Unicla UWX550-5200 compressor now has the added feature of un-loading capability which has been integrated to operate with the existing Unicla 14 cylinder swashplate technology. This compressor still retains all the advantages of compact size and weight, smooth and quiet operation, and low vibration levels for which the Unicla UWX models have become well known. The unloader control unit fitted to the rear cap of the compressor, when activated is designed to raise the suction pressure by 28-42 kPa (4-6 psi) whenever the suction line temperature is running between 0°C and 5°C. This allows system designers to have longer compressor running cycles for better cabin de-humidification and even temperatures.

Hose Ports

The Suction Port is situated on top of the compressor and the Discharge Port can be taken from either the left or right hand side. Both ports are fitted with a manifold assembly which has back seating capability via a stem valve. The hose flange on each manifold is fitted with a copper male spigot to 35mm (FS) female solder fitting. Service valve and pressure switch access ports are also fitted.

Thermal Protection

Thermal protection is provided by a thermal cut-out switch fitted to the discharge side of the hose port manifold. This normally closed switch is set to open circuit the clutch power supply when the discharge line reaches 100°C, and to re-set at 80°C. This provides protection to the compressor from over-heating and excessive discharge super heat. For more information regarding super heat recommendations for Unicla compressors please refer to pages 4-6 of Unicla Service Information booklet.

Mounting

Unicla 440 and 550 series compressors are available in special UWX configuration, which is the Unicla system of allowing multiple direct mounting points on the compressor. Four mounting points are situated on the left, right and bottom of the compressor, making a total of twelve points. Each point is a 12mm x 25mm threaded hole which allows for excellent flexibility in engine mounting.

Service Valves

Low and high side service valves are fitted as standard and can be easily removed if not required. The low side valve can be interchanged with the oil separator port, **Unicla part no: 35401-00010**.

Oil Return Port

A Unicla Oil Return Port is fitted at the top of the compressor as standard and can be interchanged with the low side service port.

Clutches

A diverse range of clutches are available in AA, B section and Polygroove, and 12 or 24 volt.



Technical Specifications

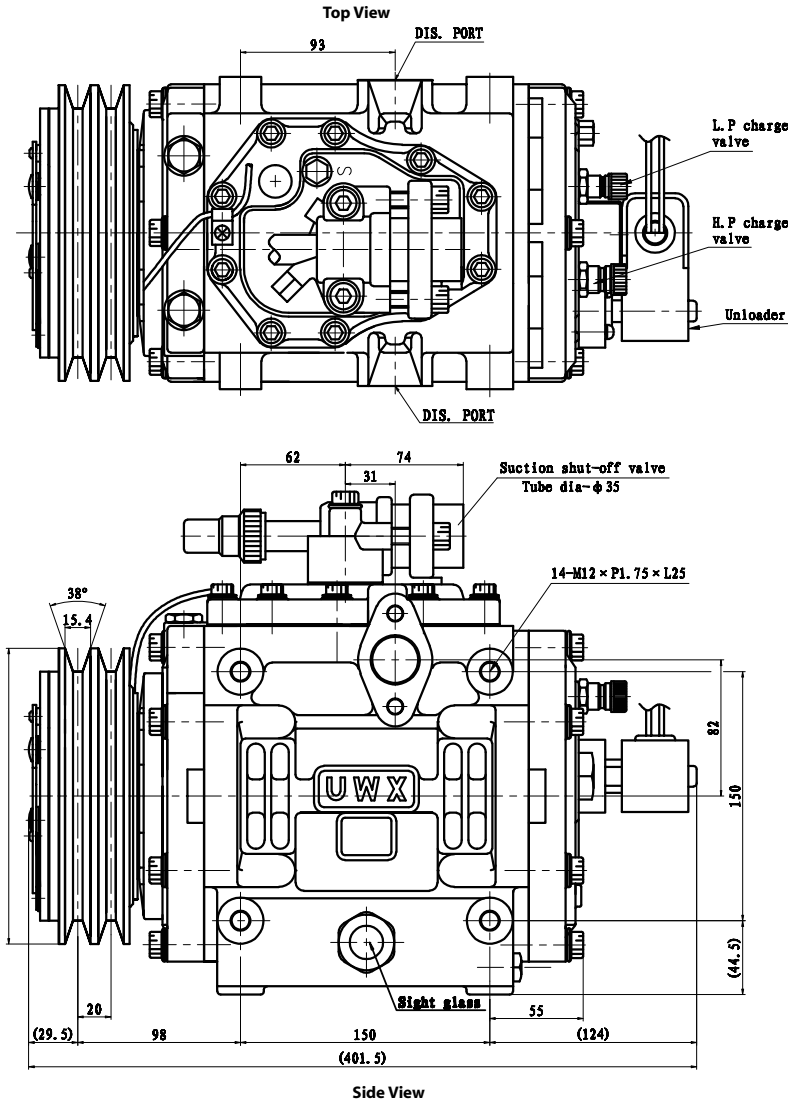

UWX550-5200 side and rear view

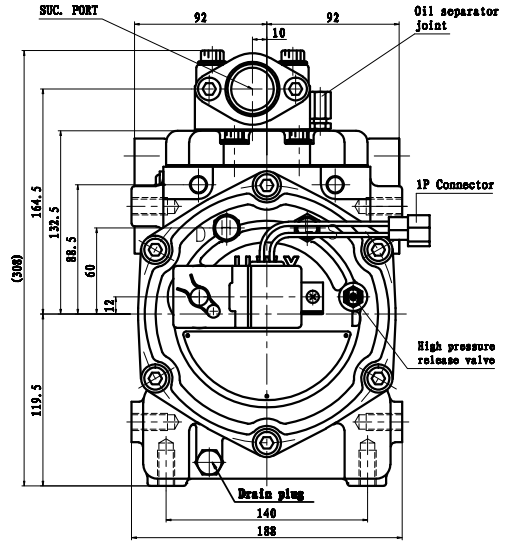

Specifications		Operating conditions	
Displacement	607 cc/rev.	Pressure suction	1.86 kg/cm ² G
No. of cylinders	14	Pressure discharge	15.5 kg/cm ² G
Max momentary speed	4500 rpm	Super heat	10°C
Lubricant	Unidap 7 (PAG)	Sub cooling	9°C

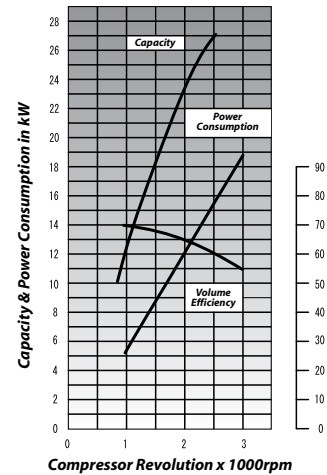

UWX550-5200 Performance data operating with R134a

Clutches Available for Unicla 550 Series Compressors

Pulley Diameter (mm)	Power	
	12V	24V
Type UXW550	210	24V
AA Groove	•	•
B Groove	•	•
BB Groove	•	•
8 Groove	•	•

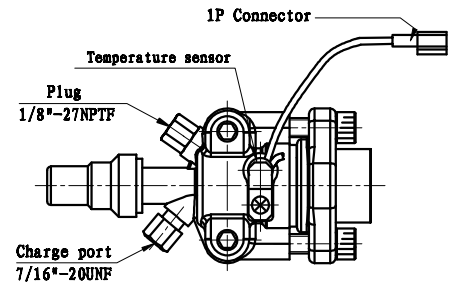

UWX550-5200 Hose Manifold / Shut-off Valve Detail

For detailed information about Unicla recommendations on such areas as fitting compressors in special applications, measuring compressor thermal and pressure loads, and calculating extra oil requirements in larger systems, we recommend you visit our website where expert advice from Unicla engineers can be found.



Unicla International Limited

Unit 1209-1210, 12F, Manhattan Centre, 8 Kwai Cheong Rd,
Kwai Chung, N.T., Hong Kong. Phone (852) 2422 0180 Fax (852) 2422 0680
Email: sales@unicla.hk Website: www.unicla.hk

Distributed by: